



Simulation and construction of an automatic trash bin system with a mobile wireless technology

Samson D Yusuf^{1*}, Kabiru M Osu², Abdulmumini Z Loko¹, Ibrahim Umar¹

¹ Department of Physics, Nasarawa State University, Keffi, Nigeria

² Department of Biology/Integrated Sciences, Jibwis College of Education Keffi, Nasarawa, Nigeria

Abstract

Solid waste management is a serious problem in most developing countries especially Nigeria, where the population is exploding and majority of the population still use open waste dumps that contributes to environmental pollution and degradation. Proper waste management system is very vital for a cleaner and safer environment. In this study, simulation and construction of an automatic trash bin system with mobile wireless technology was carried out using Atmel AT89S51 microcontroller. The circuit was simulated using Proteus ver8.0 via Arduino Uno IDE programming language using embedded C language. The various stages include HC-SR04 ultrasonic sensor, SIM800L GSM modem, microcontroller unit, and regulated power supply unit. The device prototype was constructed on a Vero board and tested for continuity, power ON and validity test for different trash levels. Results shows that, the device can sense the waste level in the bin and then send an SMS to the user when the waste level reaches a certain threshold value to alert the user that the bin is full. The device can be used for effective waste monitoring in homes and commercial areas for proper waste management for a cleaner and healthy environment.

Keywords: trash bin, GSM module, microcontroller, proteus design suit, Arduino Uno, ultrasonic sensor

Introduction

Waste which is one of the sources and causes of environmental pollution has been defined by Bashir and Banday^[1] as any solid, semisolid, liquid or contained gaseous materials discarded from industrial commercial, mining or agricultural operations and from community activities. Most daily human activities generate waste as moderate amounts of waste can be found in any environment inhabited by human beings which requires to be properly managed to protect human health, environment and ecological development while enhancing aesthetics^[2]. Poor management of solid waste within cities, towns and villages is a major problem in today's society particularly in urban settlements and big municipal areas where large quantity of solid waste is generated due to high human population^[3,4].

The common methods of solid waste disposal especially in Nigeria is the use of waste bins for collection. The challenge in waste collection and monitoring of trash bins is quite complicated as the wastes are widely distributed, extensively generated, and mostly unmanaged due to lack of proper monitoring, and filing status identification. Also trash bins are placed in public, left unclear when they are completely packed with overflowed wastes as the threshold filling limit of the bin exceeds^[5]. This causes the waste spill over to the surrounding areas of the bin resulting in unhealthy, polluted environments. In this existing method, the garbage collector workers have to look through all the different areas where the bins are placed in order to collect the waste without the knowledge of the bin status^[1,6]. This is a complex and time consuming process because in this case, two possibilities present; either there is no waste for collection, or the bin has overflowed. Also, rising waste disposal costs and high visibility of waste collection operations are forcing residents to demand efficient collection and disposal of solid waste^[7]. Cleaning of garbage bin in time will ensure proper cleanliness of the surrounding, as such, there is need for proper and efficient waste management for a hygienic society and for a better world as a whole^[1,8].

In order to overcome the problems faced due to the existing method, a new way of approaching the waste management automatically is the use of an automatic trash bin system. A lot of researches have been done on different aspect of automated trash bin system, but a few works have been done on mobile wireless technology which allows us to monitor the trash bin without having any physical attention or visit^[9]. In view of the above, the objective of this study is to simulate and construct an automatic trash bin system with mobile wireless technology using electronic workbench Proteus 8.0 and a microcontroller. The device will allow domestic and corporate user to monitor their bin status over a period of time for increasing overall productivity by ensuring collections occur only when needed, over-filling is eliminated, collection costs are reduced and residents enjoy an eco-friendly waste monitoring solution.

Materials and Methods

1. Materials

The materials and their specification that were used for the simulation and construction of an automatic trash bin system with a mobile wireless technology includes AT89S51 microcontroller, SIM800L GSM modem, HC SR04 ultrasonic sensor, 5V/500mA step down transformer, and Proteus 8.0 software.

2. Methods

The methods for implementation of the automatic trash bin system with a mobile wireless technology includes simulation, flowchart, algorithms, choice of programming language, hardware construction, and circuit analysis (testing) method.

2.1 Simulation Methods

The simulation of the circuit for the automatic trash bin system with a mobile wireless technology was carried out in stages according to the block diagram presented in Fig. 1. The circuit was simulated using Proteus ver8.0 software. The stages for the implementation of the circuit includes ultrasonic sensor unit, microcontroller unit, GSM module unit, and power supply unit.

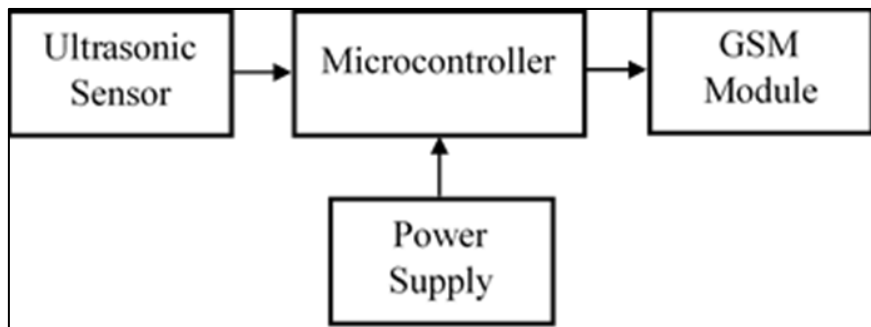

Fig 1: Block diagram of the proposed system

2.1.1 Ultrasonic Sensor Unit

The HC-SR04 ultrasonic sensor was used as the ranging device. This sensor was chosen since it was relatively low cost and interfaced easily with our AT89S51 microcontroller. This ranging sensor has a detection distance from 2cm to 4m with up to 3mm accuracy. It operates on 5V DC and 15mA [10]. The sensor has 4 pins: Vcc, Trig, Echo and GND. A pulse is sent to the trig pin to start the ranging and the echo pin returns a signal when the ranging is complete. The ultrasonic sensor works by sending out a sound wave and waiting to hear it back as an echo and then calculate the time difference between when the wave is sent and received. Since it operates on 5 volts, it can be hooked directly to a microcontroller [11]. A simple ultrasonic module is shown in Fig. 2.



Fig 2: Ultrasonic sensor [10]

2.1.2 SIM800L GSM Modem Unit

The SIM800L GSM modem used in this work is used to send or receive messages and make or receive calls just like a mobile phone by using a SIM card by a network provider. To be connected to a cellular network, the shield requires a SIM card provided by a network provider. When the modem is powered up by external power supply, the Network LED will blink every second. After the Modem registers in the network (it takes 10-60 seconds), this LED will blink in step of 3 seconds at slow rate. The modem is now registered with the network at this stage and we can start using the modem for our application [10]. The SIM800L GSM modem is shown in Fig. 3.

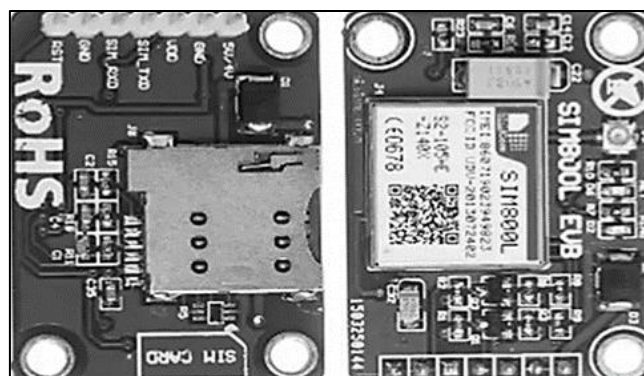

Fig 3: SIM800L [12]

2.1.3 Microcontroller Unit

A microcontroller is a device that takes input from the device it is controlling and controls the device by sending signals to different components in the device. The AT89S51 microcontroller is a Low-power, high-performance CMOS 8-bit microcontroller with 4KB of In-System Programmable (ISP) flash memory. It uses Atmel’s high-density, non-volatile memory technology which is compatible with the industry-standard 80C51 instruction set and pinout. The on-chip flash allows the program memory to be reprogrammed in-system or by a conventional non-volatile memory programmer [13, 14]. The Atmel AT89S51 is used in this study because it is a powerful microcontroller which provides a highly flexible and cost effective solution to embedded control applications since it combines a versatile 8-bit CPU with In-System Programmable Flash on a monolithic chip. It is responsible for receiving the echo signal and determines whether the dustbin is full or not by using the time of arrival of the echo signal. A simple microcontroller AT89S51 and its pinout is shown in Fig. 4.

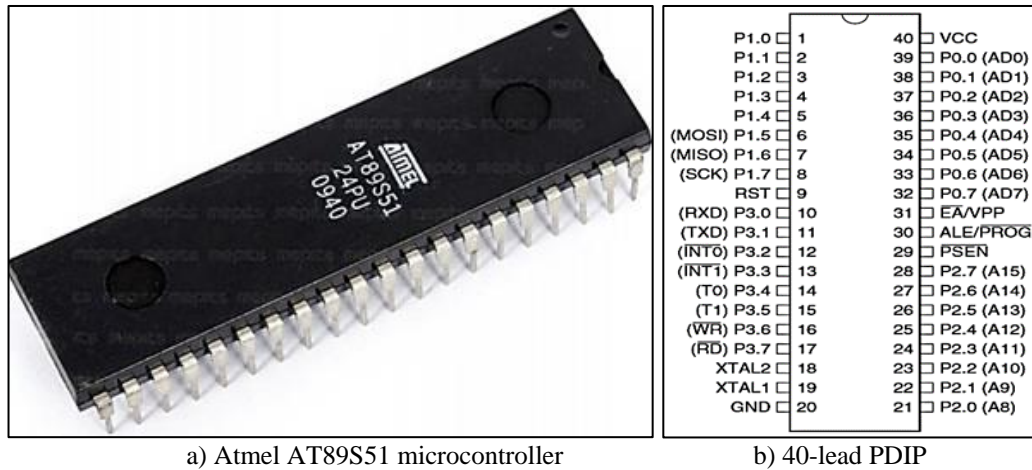

Fig 4: Atmel AT89S51-24PU PDIP-40 Microcontroller [14]

2.1.4 Power Supply Circuit

The voltage from the main source is 230V AC but some sections of the circuit will need 12V DC while some 5V DC. Therefore, a step-down transformer was used to get 15V AC, 500Ma. The 15V AC generated by the transformer (TR1) was then converted to DC via the use of a rectifier (BR1). Afterwards, 1000uf capacitor (C1) was used to filter off ripples, while a 12V voltage regulator (7812) was used to generate standard 12V and 5V voltage regulator (7805) was used to generate 5V. The Power Supply unit is shown in Fig. 5.

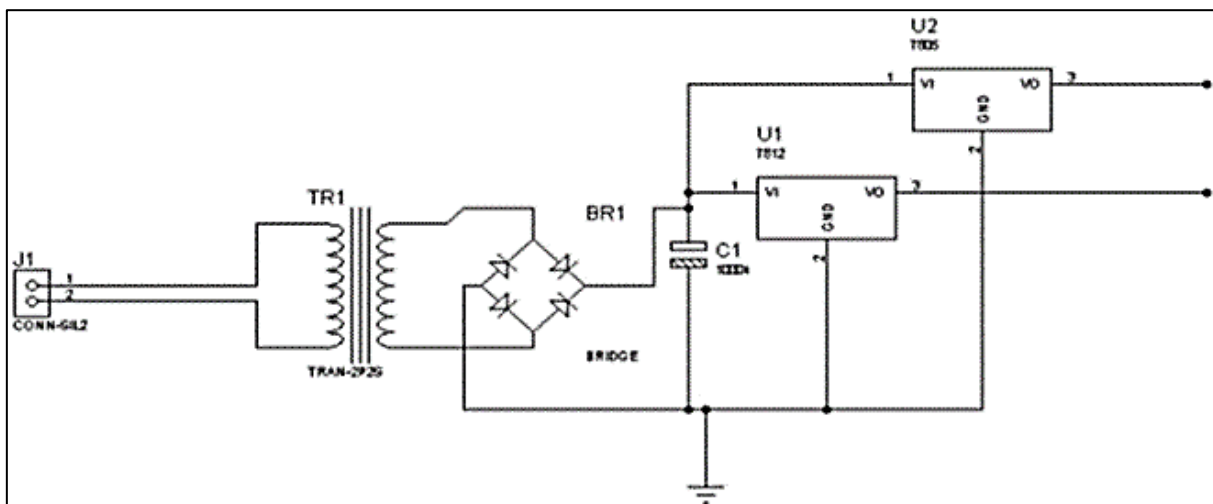

Fig 5: The regulated power supply

2.2 System Flowchart

The flow chart for the automatic trash bin system with mobile wireless technology is shown in Fig. 6.

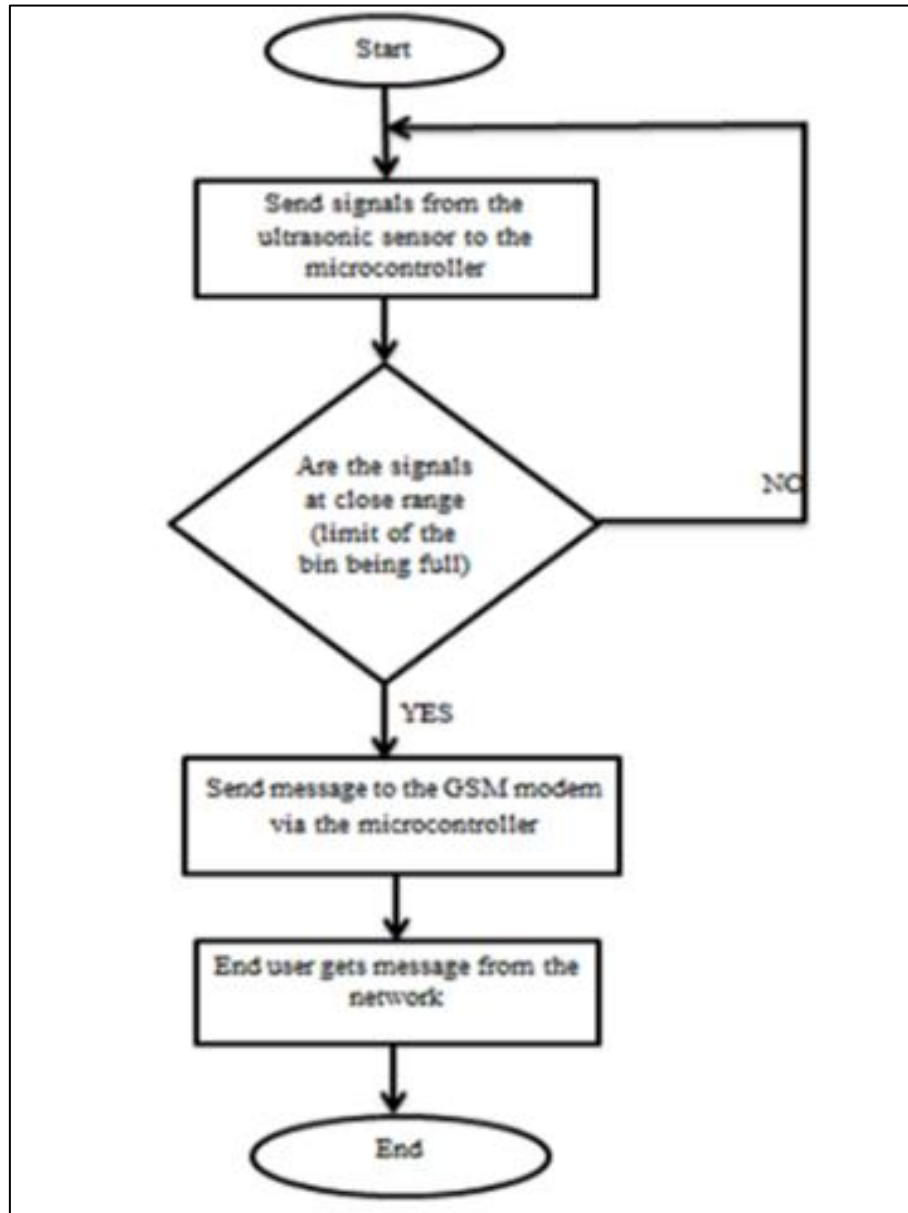

Fig 6: Flowchart for the proposed system

2.3 System Algorithm

The algorithm that explains the flowchart for the automatic trash bin system with mobile wireless technology is presented as follows:

1. Start
2. Microcontroller gets signals from sensor
3. Are the signals at close range?
4. If no, keep sensing distance of object
5. If yes, send a code to GSM Modem
6. GSM module interprets the information's and sent to end user via the network
7. End

2.4 The Choice of Programming Language

The Atmel AT89S51 microcontroller was programmed via the Arduino Uno board using the Arduino programming language. The Arduino is an open-source development board or a set of boards with its own dedicated IDE (Integrated Development Environment). The basic software program is written using the embedded C language programming which was chosen because it is more compatible with embedded processors/controllers. C language is also used mainly to implement those portion of the code where very timing accuracy, code size efficiency are key requirements.

2.5 Hardware Construction Method

The circuit construction was carried out in stages according to the block diagram shown in Figure 1. The components were first assembled on electronics breadboard to ensure proper terminal connections and then transferred on to a Vero board for permanent soldering using the soldering iron and MBO 1mm wire lead solder, +183°C melting point. However, too much Lead was avoided

to prevent clumsiness and bridging of the component to each another.

2.6 Circuit Testing Method

Components testing was carried out before fixing them on the Vero board. Also Continuity test and Power ON test were carried out during construction to ensure proper functioning of the circuit and to ensure that no components in the circuit undergo heating when the device is in use and also to avoid loading and impedance mismatch of one stage and another.

2.6.1 Continuity Test

This was employed to verify whether current flows in a complete circuit, to ascertaining the circuit free from any electrical open paths resulting from poor soldering, improper usage of the soldering iron, component failures, as well as, presence of bugs in the circuit diagram. In this work, this test was performed using a multi meter. The meter kept in buzzer mode and connected its ground terminal to the ground, then connected both the terminals across the path that needs to be checked, so that it makes a beep sound if there was continuation.

2.6.2 Power ON Test

This test is carried out to ascertain that the voltage at the different terminals is according to the requirement. It was carried out without microcontroller to protect the microcontroller from damage by any excessive voltage and possible heat [15]. In this study, a multi meter was used to carry out this test.

2.6.3 Performance Evaluation Test

The performance evaluation was carried out to ascertain the functionality of the constructed device. This was carried out to test the working condition of automatic trash bin in sending message to the user via the GSM module whenever the bin is full. The device was tested when the bin was empty, when there was trash at various levels and when the bin was full.

Results

1. Simulation Results

The simulation was carried out according to the block diagram in Fig. 1 and the result of the simulation for the general circuit of the automatic trash bin system with mobile wireless technology is presented in Fig. 7.

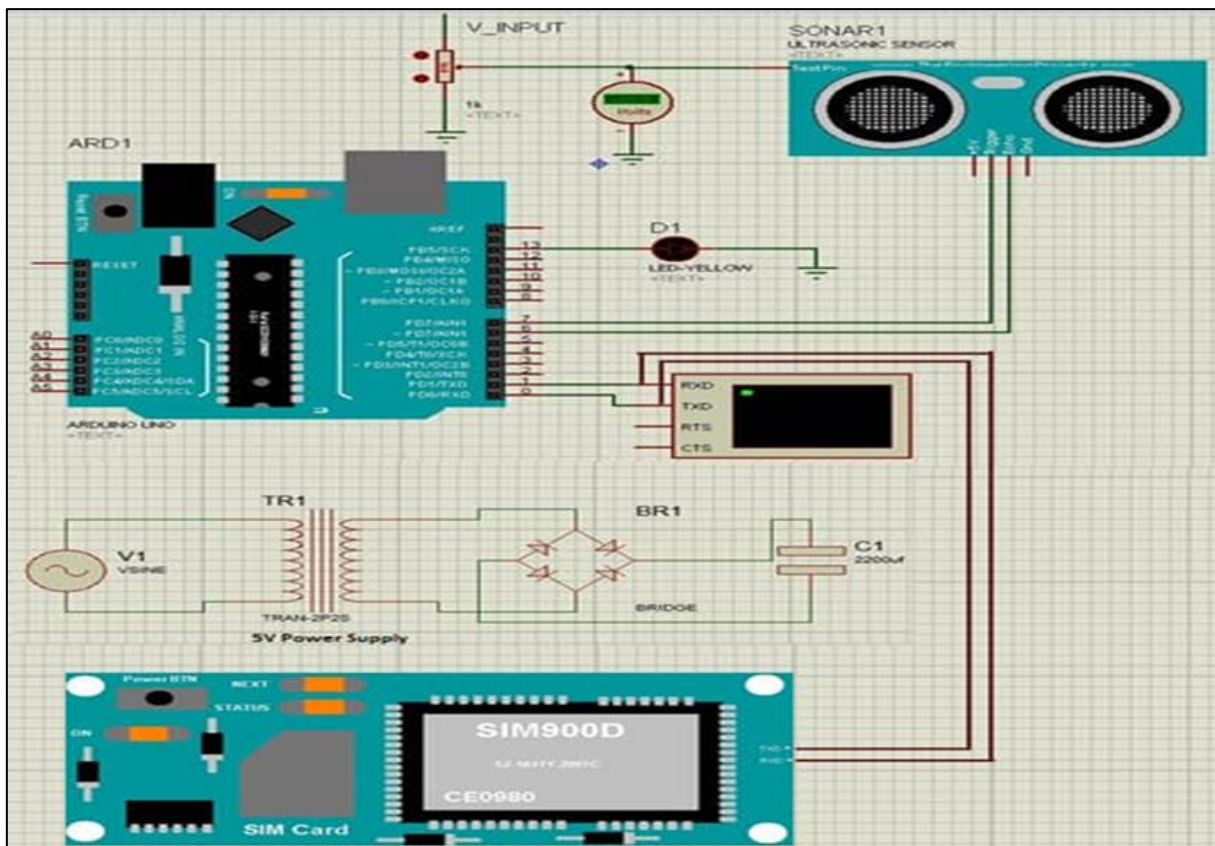

Fig 7: Simulated general circuit of an automatic trash bin system with mobile wireless technology

2. Hardware Construction

2.1 Circuit Construction

The construction was carried out first on a bread board to ensure that the circuit is working as required, then transferred to the Vero board for permanent soldering using a 40 Watt soldering iron to minimizes damage to electrical components caused by much heat from a higher wattage iron. The top view of the constructed device on Vero board is shown in Fig. 8.

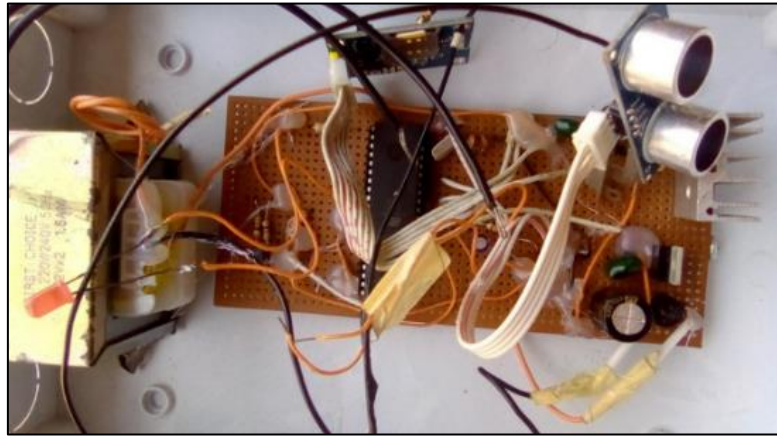

Fig 8: Top view of constructed device on Vero board

2.2 Casing and Packaging

A casing measuring 63cm x 45cm x 40cm was finally provided to the system for mechanical protection. It is provided with 1no. of 45cm x 13cm hole for waste compartment, 1no. of 19cm x 10cm hole for detection platform, a platform where the waste is to be detected and 1no. of 19cm x 17cm hole for electronic compartment. The complete isometric diagram of the casing showing its three views (Front, Side and Top) and the various dimensions is shown in Fig. 9, while the complete packaged device with full casing showing its top and side view is shown in Fig. 10.

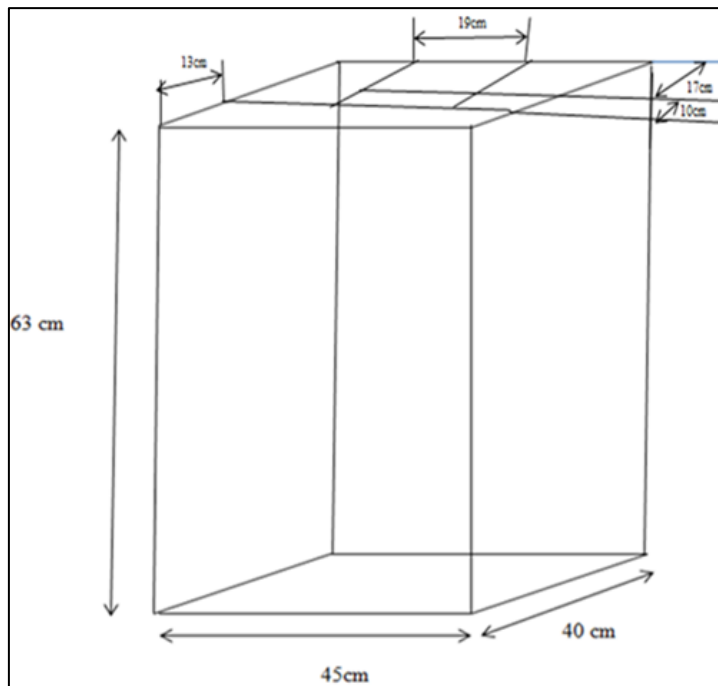

Fig 9: The isometric diagram of the casing



a) Top view

b) Side view

Fig 10: Complete packaged device with full casing

3. Analysis of Testing

3.1 Continuity Test

In this study, the multi meter was used to perform this test. The multi meter was set at the continuity mode and the two ends of the probe was placed at the ends of a particular wire that is being checked for continuity, if there is a negligible resistance between the ends of the wire or path or the multi meter buzzer sounds then, the ends or path is continuous. Test results shows that the soldering was perfectly done as there were no short circuits along the paths, or broken conductors, damaged components, or excessive resistance along the circuit.

3.2 Power ON Test

In this test, we took a multi meter and put it in voltage mode and the output of the transformer was checked for 15V AC. This voltage was then applied to the voltage regulator which serve as its input. The input and output to the voltage regulator were checked to make sure the voltage obtained is 15Vdc input and 5Vdc output. This 5Vdc output is fed to the microcontroller at the 40th pin. The voltage level at 40th pin and the other terminals were also checked, making sure they met specified requirement since same 5Vdc (V_{CC}) used for both ultrasonic sensor and GSM module in this system.

3.3 Performance Evaluation Test

To ascertain the functionality of the constructed device a performance evaluation was carried out to test the working condition of automatic trash bin in sending message to the user via the GSM module for various trash levels i.e. when the bin was empty, with trash at various levels and when the bin was full. However, the number of times the device send SMS to the user was recorded and presented in Table 1.

Table 1: Performance validation test result for automatic trash bin

S/N	Test Cases	Trash Level (CM)	% of Fullness	LED Indicator	Mobile SMS Sent & Received	Validation
1	T_1	0.00	100.00	OFF	NO	PASS
2	T_2	9.00	85.71	OFF	NO	PASS
3		18.00	71.43	OFF	NO	PASS
4		27.00	57.14	OFF	NO	PASS
5		36.00	42.86	OFF	NO	PASS
6	T_3	45.00	28.57	OFF	NO	PASS
7	T_4	54.00	14.29	ON	YES	PASS
8	T_5	63.00	0.00	ON	NO	PASS

Table 1 gives the experimental validation for automatic trash bin test cases T_1 to T_5 . After conducting the experimental studies on the system, it was identified that all the defined test cases were validate. At T_1 or empty level, T_2 or intermediate level and T_3 or above intermediate level, It was observed that validation test was passed when LED indicator is OFF and no message is received by the user. At T_4 or maximum level, validation test was passed when end user received mobile message and LED indicator is ON. It was also observed at T_5 or threshold limit exceeded, that validation test was passed when LED indicator is ON and no mobile message is received by the user. The output result showing the bin status for test case 4 i.e. at maximum level when the automatic bin sent SMS to the user is shown in Fig. 11.

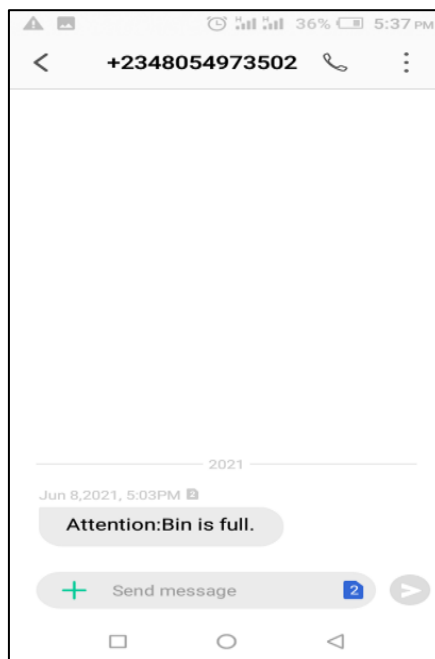

Fig 11: Output result of test case four (T_4)

Discussion

The automatic trash bin system with mobile wireless technology is identified to perform well as per the designed consideration giving the validations in the test cases as well as in status identification. After conducting the experimental studies on the developed system, it was identified that all the defined test cases were validate at T_1 or empty level, T_2 or intermediate level and T_3 or above intermediate level, T_4 or maximum level and T_5 or threshold limit crossed respectively. At a percentage fullness of 14.29% the user is given a notification to take out the trash. The status of the bin can be accessed by the user through the mobile message. The system is able to monitor the level of the empty bin but the message is not sent when the bin is still empty. As waste is thrown into the bin, the system keeps on getting different levels of waste in the bin. When the threshold level is reached, the message is sent to the user. When the trash is emptied, the user restarts the system by pressing the restart switch. The results obtained are similar to Monika, Rao and Thakker^[8] who proposed a smart dustbin based on IoT using Arduino Uno board which was interfaced with a GSM modem and an ultrasonic sensor, Meghana^[16] who proposed an IoT-based smart garbage system (SGS) with the aim to reduce the amount of food waste but the system uses three ultrasonic sensor where the data are sent to the garbage analyzer instead of mobile phone, Kasliwal and Suryawanshi^[17] who proposed a model of garbage management using Internet of things for smart cities using Arduino Uno board with Atmega328 in a two way communication system of GSM and GUI in a MATLAB environment, and Debmalaya *et al.*^[18] who design an embedded environment informer for waste disposal cleaning using ARM7 microcontroller based on ZigBee, while present research uses Atmel AT89S51 microcontroller and ultrasonic sensor.

The design in the present study differs from that of Sathish^[19] who worked on IOT based smart garbage alert system using Arduino Uno and used web server instead of GSM module, Dhikhi and Purushotham^[20] who proposed a smart garbage management system but used GPRS modem and RS-232 as communication interface with MATLAB while the present study used Proteus software. Also differs from that of Guerrero *et al.*^[21] who proposed a solid waste management challenges for cities in developing countries but however. They used weight sensor to detect amount of waste in the bin instead of ultrasonic sensor for detection of filled level of bin in this study, and Sureshku and Prabh^[22] who proposed a smart garbage management system using GPS and GSM but used different types of microcontroller (NODE MCU and Arduino) with GPS module where PC is to display the message instead of phone. None of the previous mentioned work carried out an experimental validity test to ascertain the performance of the device which was successfully carried out in this study.

Conclusion

The present research provides a solution to the problems encountered by domestic household and corporate user peeping through the bins and checking fill level. The system prototype is built with microcontroller based system containing ultrasonic sensor and GSM module for monitoring waste level in the bin and notifying the user through mobile SMS alert to avoid overflow of the waste that will cause pollution to the environment. The device design was simulated and the prototype was constructed, tested and obtained satisfactory results according to the simulation specifications. System performance was evaluated using test cases. Thus the system prototype can only send text to user when the sim card in use is loaded with airtime. However, to create a more responsive mobile application which have more controlled data would be an added advantage in future research. Also the system can be built using renewable energy such as solar power which will help to reduce future cost.

References

1. Bashir A, Banday SA. Concept, design and implementation of automatic waste management system. International Journal on Recent and Innovation Trends in Computing and Communication,2013;5(1):604-609.
2. Prassler E, Stroulia E, Strobel M. Office waste cleanup: an application for service robots. In Proceedings of International Conference on Robotics and Automation,1997;3(5):1863-1868.
3. Mware EM. A Smart-bin prototype for in-house waste management. Strathmore University. Message Posted to Su-plus Strathmore. Accessed on 23rd May 2020 from <http://suplus.strathmore.edu/handle/11071/5659>, 2017.
4. Glouche Y, Couderc P. A Smart waste management with self-describing objects. The Second International Conference on Smart Systems, Devices and Technologies (SMART'13),2013;4(2):63-70.
5. Ahmed I, Mutaz AM, Omer OI, Ahmed IM. Design and development of GSM based automated spray irrigation system prototype. Message posted to Academia. Accessed on 23rd May 2020 from <http://www.acadamia.edu.com>, 2016.
6. Lazaro EP, Alexis E, Rubio JM. Solar powered electronic trash can. International Journal of Engineering Sciences & Research Technology (IJESRT),2014;2(5):33-37.
7. Dugdhe S, Shelar P, Jire S, Apte A. Efficient waste collection system. International Journal of Engineering Sciences & Research Technology,2016;4(2):143-147.
8. Thakker S. Smart and wireless waste management. Message posted to Su-plus Strathmore. Accessed on 23rd May, 2020 from <http://su-plus.strathmore.edu/handle/11071/5659>, 2015.
9. Alexey M, Petr F, Arkady ZT, Anagnostopoulos SK. Waste management as an IoT-enabled service in smart cities. International Journal of Innovative Research in Computer and Communication Engineering,2017;3(1):4-7.
10. Pantech Solutions. Microcontroller AT89S51: Electronics Component's. Accessed on 10th March, 2021. Available: <https://www.pantechsolutions.net/at89s51> 2020.
11. Michael E, Otaru CO, Liman AD, Bomoi MI, Awotoye B. Design and development of a smart waste bin. International Journal of Scientific and Technology Research,2017;6(10):2-6.
12. Ngosa W, Kapata L, Katawa S, Phiri DV, Sinonge J. GSM and GPS based garbage and waste collection bin overflow management system for Kitwe city council. Message posted to Ijert. Accessed on 23rd May, 2020 from <http://www.ijert.org>, 2018.
13. Microchip. AT89S51 Atmel Microcontroller IC. Accessed on 15th April, 2022. Available:<https://www.microchip.com/en>

- us/product/AT89S51, 2022.
14. Pantech Solutions. AT89S51 Microcontrollers-IC's. Accessed on 15th April, 2022. Available: <https://www.pantechsolutions.net/at89s51>, 2021.
 15. Jha DK. Computational Physics, 1st ed., Discovery publishing House PVT, Ltd., New Delhi, 2016, 223-268.
 16. Meghana KC. IOT - based smart garbage system (SGS). International Journal on Smart Sensing and Intelligent Systems,2017:8(1):12-22.
 17. Kasliwal MH, Suryawanshi SB. A model of garbage management using Internet of things for smart cities. International Journal of Engineering Sciences & Research Technology,2018:40(3):4-23.
 18. Debmalya B, Waikhom R, Kiruthika P, Banu P. Analysis and design of an embedded environment informer for waste disposal cleaning. International Conference on Green Computing, Communication and conservation of Energy,2013:2(1):23-33.
 19. Sathish VP. IOT based smart garbage alert system using Arduino Uno. International Journal for Computer Science,2016:5(3):74-88.
 20. Dhikhi TM, Purushotham JS. Smart garbage management system. International Journal of Innovative Research in Science, Engineering and Technology,2016:3(7):34-45.
 21. Guerrero LA, Maas G, Hogland W. Solid waste management challenges for cities in developing countries. Journal of Waste Management,2016:4(3):12-23.
 22. Sureshku SM, Prabh R. Smart garbage management system using GPS and GSM. International Journal of Engineering Sciences,2019:6(4):55-44.